

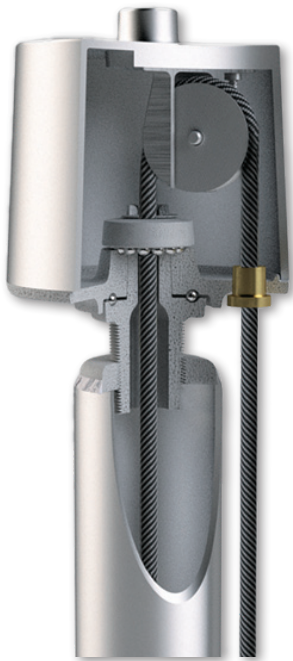

Internal Halyard Revolving Truck



Internal Halyard Revolving Truck Cutaway



# INSTALLATION INSTRUCTIONS IH-WINCH-100

## INTERNAL HALYARD FLAGPOLE SYSTEM

### GROUND SET and SHOE BASE

#### **WARNING:**

To prevent staining the flagpole must be stored in a dry place OR all packaging must be removed immediately after receiving shipment.

## FOR QUICK AND PROFESSIONAL INSTALLATIONS READ ALL INSTRUCTIONS BEFORE PROCEEDING

Lay out all flagpole components. If a part is missing from the attached parts diagram, please contact your American Flagpole Dealer for replacement.

**STEP 1** - Remove all wrapping materials and place unwrapped flagpole on cribbing or other wood support on ground (*preferably in a covered dry area*). If flagpole is **MULTI-SECTION**, carefully lay sections out in proper order, grouping flagpole sections with like match marks. Sections **MUST BE STRAIGHT & LEVEL** while sliding together. Line up match mark numbers, imprinted at each section, for proper fit. Lightly sand away any burrs that may be present on the male section or in the upper section of the joint. A small amount of lubrication (*silicone or dish washing liquid – by others*) may be applied to the male portion of the joint for easier fitting. Start with the bottom sections and work toward the top. Begin sliding the two sections, rolling the flagpole by 180° with every 2 to 3 inches to facilitate an easier fit. If extreme difficulty is found in fitting the first 6 inches together, pull back apart and cool the male section with ice for several minutes. A sledgehammer and block of wood (*to protect the flagpole from direct impact*) may be necessary on larger poles to complete the assembly of joints. American Flagpole suggests the use of an epoxy adhesive for flagpoles 60' and greater.

**STEP 2** - Identify parts and place them along the flagpole according to the parts diagram.

**STEP 3** - Open truck (*PART B*) by removing screws. Feed taped cable end of cable assembly (*PART D*) up through bronze fitting in truck housing, up over the pulley inside the truck's hood, and back down through the threaded spindle of the truck assembly. Pull a few feet of cable through truck and re-assemble truck.

**VERIFY HOOD IS REPLACED SUCH THAT INSIDE PULLEY IS DIRECTLY OVER CABLE ENTRANCE.** Feed the cable down through the flagpole until you can pull it out through the winch door near the base of the flagpole (*this may require a fish tape*). Coil cable and secure to outside of flagpole with tape.

**STEP 4** - Starting with the finial ball (*PART A*), screw the ball's spindle into truck (*PART B*). **DO NOT GRIP BALL TO TIGHTEN. GRIP SPINDLE/ROD WITH VISE GRIPS AND TIGHTEN.** Tighten all nuts and set screws. An epoxy or Loc-tite type product is recommended on all connections (*supplied by others*).

**STEP 4** - Attach the truck (*PART B*) with ball by screwing into the threaded top of the flagpole. **DO NOT EPOXY SPINDLE OF TRUCK.**

**STEP 5** - With cable fed down through pole, wrap the beaded retainer slide sling (*PART G*) around the flagpole and attach with the shackle provided at the end of halyard cable assembly. Carefully screw the threaded stem of the revolving truck (*PART B*) to the top end of the flagpole, being careful not to pinch or jam cable in threaded area. The use of thread-ease type product is recommended on this connection in order to tighten completely. Tighten truck with pipe wrench until tight. Once truck is fastened it should revolve freely.

**STEP 6** - Before standing flagpole, slide the flash collar (*PART J*) up from bottom (*or down from the top*) and secure at the location of the access door with tape on the underside of flash collar to prevent slipping. Coil up excess cable if necessary and either stuff inside flagpole or tape just outside winch hole while erecting pole. The winch and lock may be installed now or after erection.

**STEP 7** - Determine the style of winch (*PART I*) you received. The "small" winch will have a handle that passes into the winch to allow cranking. The "large" winch will have a handle (*PART H*) that connects to a machined bolt on the side of the winch for cranking. If you have the "large" winch, instructions are included in the plastic bag with the bolts and nuts for cable attachment. If you have the "small" winch (*lubrication not required*), the cable attachment should be completed as follows:

- 1) Loosen the screw on the drum of the winch,
- 2) Sit the stop sleeve into the hole below the screw with cable lying into the grooves on either side,
- 3) Tighten screw onto stop sleeve securely. Fasten winch onto plate with pre-drilled holes inside access door and fasten with screws provided.

Once installed, handle should extend into side of flagpole and proceed through or fit over winch. Using the directions shown on the handle of the winch, you will want to pull the excess cable onto the winch, keeping tension in cable at all times. The winch allows the flag to fly in any position on the flagpole and can be lowered by cranking the handle in the opposite direction.

**STEP 8** - Stand flagpole into previously installed Ground Sleeve (*Ground Set Installation*) - (*PART K*) or onto anchor bolts (*Shoe Base Installation*). This may require the use of a crane or backhoe for larger flagpoles. Always choke multiple section poles below

lowest joint as a safety precaution. Caution: During installation, the flagpole should be assembled as close as possible to the final support point. Professionals experienced in such installations should perform rigging and lifting. During lift, keep clear of the area and reach of the flagpole path. Do not pass flagpole overhead. When installing multi-piece flagpoles, arrange the rigging for the lift in such a way that weight of the flagpole sections is supported from the bottom of the flagpoles so that the flagpole joints are pushed together, not pulled apart, during the lift. Keep clear of power lines.

**STEP 9A (GROUND SET)** - After inserting flagpole into Ground Sleeve (corrugated tube), plumb flagpole with wooden wedges (supplied by others). Fill space between ground sleeve and flagpole with tamped dry sand. Fill ground sleeve 6" to 8" at a time and tamp as you fill. Fill ground sleeve with sand to about 2" from top. Then cap off with waterproof cement. For PVC ground sleeve, insert flagpole into plastic sleeve, turn to align truck assembly with the wind, plumb pole, fill remaining void with dry sand, and top off with thin layer of waterproof cement or caulking.

**STEP 9B (SHOE BASE)** - After placing the flagpole on top of the anchor bolts, install flat washer, lock washer, and hex nut. Tighten nut and verify that all threads are fully engaged.

*NOTE: AN INSTALLATION USING "DOUBLE NUTS" IS NOT RECOMMENDED BY AMERICAN FLAGPOLE.*

**STEP 10A (GROUND SET)** - After waterproof cement and silicone has dried slide flash collar (PART J) down into position and caulk joint with matching color silicone to seal the space between the flagpole and the flash collar.

**STEP 10B (SHOE BASE)** - After the nuts have been tightened, slide flash collar (PART J) down into position and caulk joint with matching color silicone to seal the space between the flagpole and the flash collar.

**STEP 11** - After flagpole is mounted, lower halyard with winch handle. Attach the Plastic Covered Counterweight (PART F) and Snap Hook with Neoprene Cover (PART E) to the shackle provided at the end of halyard cable assembly. Snap Hook Assemblies (PART C - Wire, Snap Hook, Snap Hook Cover, and Wire Attaching Clamp) installed onto the wire halyard in positions based on flag size will complete the installation.

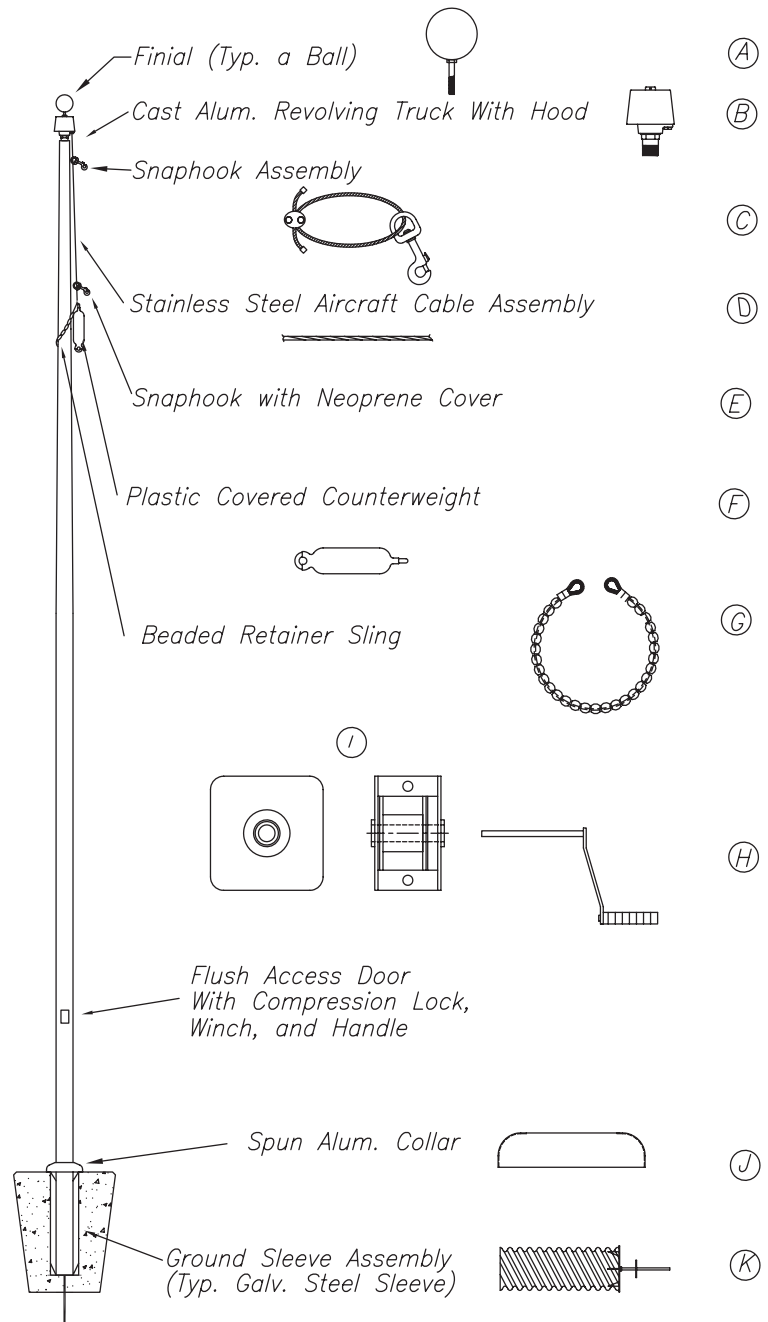

## GROUND SLEEVE WITH STEEL LIGHTNING SPIKE INSTALLATION

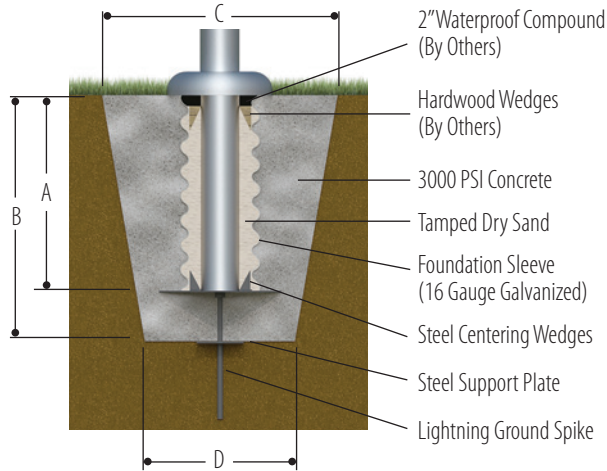

| EXPOSED MOUNTING HEIGHT | Ground Set |       |     |     |
|-------------------------|------------|-------|-----|-----|
|                         | A          | B     | C   | D   |
| 20'-0"                  | 2'-0"      | 2'-6" | 30" | 24" |
| 25'-0"                  | 2'-6"      | 3'-0" | 36" | 24" |
| 30'-0"                  | 3'-0"      | 3'-6" | 36" | 24" |
| 35'-0"                  | 3'-6"      | 4'-0" | 36" | 30" |
| 40'-0"                  | 4'-0"      | 4'-6" | 45" | 36" |
| 45'-0"                  | 4'-6"      | 5'-0" | 45" | 36" |
| 50'-0"                  | 5'-0"      | 5'-6" | 50" | 42" |
| 60'-0"                  | 6'-0"      | 6'-6" | 60" | 48" |
| 70'-0"                  | 7'-0"      | 7'-6" | 60" | 48" |
| 80'-0"                  | 8'-0"      | 8'-6" | 72" | 48" |

NAAMM's Metal Flagpole Manual offers basic suggestions on foundation measurements in firm, dry soil only using dry tamped sand and 3000 PSI concrete. Soil conditions vary by site. Exact foundation requirements should be verified by a Structural Engineer with knowledge of soil conditions in your locality.

## SHOE BASE FOUNDATION INSTALLATION

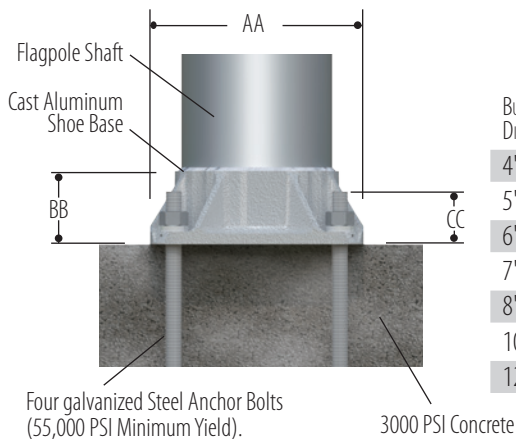

| BUTT DIAMETER | Shoe Base      |                |                    |               |                      |
|---------------|----------------|----------------|--------------------|---------------|----------------------|
|               | AA BASE SQUARE | BB BASE HEIGHT | CC BOLT PROJECTION | BOLT DIAMETER | BOLT CIRCLE DIAMETER |
| 4"            | 7-1/2"         | 3"             | 2"                 | 3/4"          | 6-1/2" - 8"          |
| 5"            | 7-1/2"         | 3"             | 2"                 | 3/4"          | 7 1/2" - 8"          |
| 6"            | 9-3/4"         | 3-1/2"         | 2-3/4"             | 1"            | 9" - 10"             |
| 7"            | 10-1/2"        | 3-11/16"       | 2-3/4"             | 1"            | 10" - 11"            |
| 8"            | 11-1/4"        | 3-15/16"       | 2-3/4"             | 1"            | 11" - 12"            |
| 10"           | 14"            | 4-7/8"         | 3-1/4"             | 1"            | 14" - 15"            |
| 12"           | 17"            | 8"             | 3-3/4"             | 1-1/4"        | 16" - 18"            |

